

TOSHIBA Bi-CMOS Power Integrated Circuit Multi-Chip Package (MCP)

# TB6581H/HG

## 3-Phase Full-Wave Sine-Wave PWM Brushless Motor Controller

The TB6581H/HG is a high-voltage PWM BLDC motor driver. The product integrates the TB6551F/FG sine-wave controller and the TPD4103AK high-voltage driver in a single package ("2-in-1"). It is designed to change the speed of a BLDC directly motor by using a speed control signal (analog) from a microcontroller.

### Features

- A sine wave PWM drive controller and a high-voltage driver integrated in a single package.
- IGBTs arranged in three half-bridge units
- Triangle wave generator (carrier frequency =  $f_{osc}/254$  (Hz))
- Dead-time insertion (1.9  $\mu$ s)
- High-side bootstrap supply
- Bootstrap diode
- Overcurrent protection, thermal shutdown, and undervoltage lockout
- On-chip regulator ( $V_{reg} = 7$  V (typ.), 30 mA (max),  $V_{refout} = 5$  V (typ.), 30 mA (max))
- Operating power supply voltage range:  $V_{CC} = 13.5\sim 16.5$  V
- Motor power supply operating voltage range:  $V_B = 50\sim 400$  V

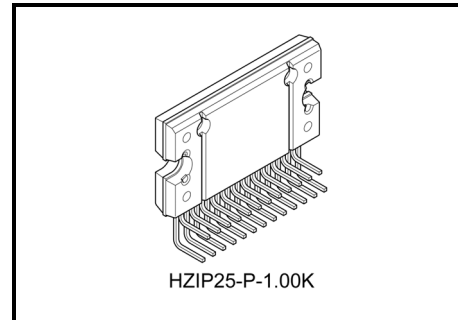

Weight:  
HZIP25-P-1.00K: 7.7 g (typ.)

#### TB6581HG:

TB6581HG is a Pb-free product.

The following conditions apply to solderability:

##### \*Solderability

1. Use of Sn-63Pb solder bath
  - \*solder bath temperature = 230°C
  - \*dipping time = 5 seconds
  - \*number of times = once
  - \*use of R-type flux
2. Use of Sn-3.0Ag-0.5Cu solder bath
  - \*solder bath temperature = 245°C
  - \*dipping time = 5 seconds
  - \*the number of times = once
  - \*use of R-type flux

**Pin Description**

Pin No.	Symbol	Description	Function
1	PGND	Grounding pin	Power ground
2	VREG	Reference voltage output	Connected to pin 5. 7 V (typ.), 30 mA (max)
3	IS	IGBT emitter pin	For connecting a current sensing resistor to ground.
4	NC	Not connected	This pin is left open and can be used as a jumper on a PCB.
5	V <sub>CC7</sub>	Signal control power supply pin	Connected to pin 2. The control stage operating voltage: V <sub>CC</sub> = 6 to 10 V
6	V <sub>refout</sub>	Reference voltage output	5 V (typ.), 30 mA (max) For connecting a bypass capacitor for internal V <sub>DD</sub> .
7	Idc	Current limit input	DC link input Reference potential of 0.5 V. This pin has a filter ( $\approx 1 \mu\text{s}$ ).
8	SGND	Grounding pin	Signal ground
9	X <sub>in</sub>	Clock input	These pins have a feedback resistor. For connecting to a crystal oscillator.
10	X <sub>out</sub>	Clock output	
11	Ve	Voltage command input	This pin has a pull-down resistor.
12	HU	U-phase position sensing input	If the position sensing inputs are all HIGH or LOW, the outputs are turned off. This pin has a pull-up resistor.
13	HV	V-phase position sensing input	
14	HW	W-phase position sensing input	
15	LA	Lead angle control input	0 to 58° in 32 steps
16	FG	FG signal output	This pin drives three pulses per rotation.
17	REV	Reverse rotation signal	For reverse rotation detection.
18	BSU	Bootstrap supply (phase U)	For connecting a bootstrap capacitor to the U-phase output.
19	U	U-phase output pin	—
20	BSV	Bootstrap supply (phase V)	For connecting a bootstrap capacitor to the V-phase output.
21	V	V-phase output pin	—
22	BSW	Bootstrap supply (phase W)	For connecting a bootstrap capacitor to the W-phase output.
23	W	W-phase output pin	—
24	VB	High-voltage power supply pin	Power supply pin for driving a motor.
25	V <sub>CC15</sub>	Power supply pin for the power stage	Power stage operating range: V <sub>CC</sub> = 15 V

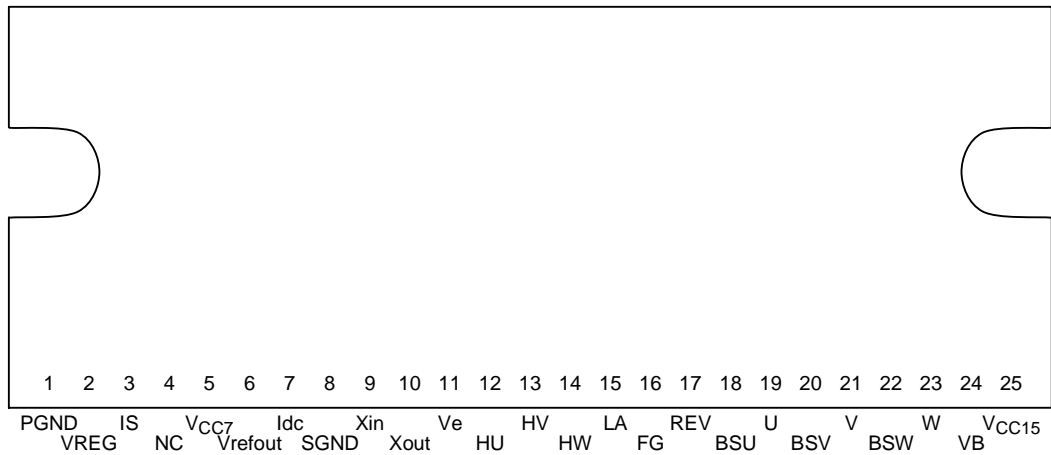
**Pin Assignment****Maximum Ratings (Ta = 25°C)**

Characteristics	Symbol	Rating	Unit
Power supply voltage	VCC7	12	V
	VCC15	18	
	VB	500	
Input voltage	V <sub>in</sub> (1)	-0.3 to V <sub>CC1</sub> (Note 1)	V
	V <sub>in</sub> (2)	-0.3 to 5.5 (Note 2)	
PWM output current	I <sub>OUT</sub>	2 (Note 3)	A
Power dissipation	P <sub>D</sub>	40 (Note 4)	W
Operating temperature	T <sub>opr</sub>	-30 to 115 (Note 5)	°C
Storage temperature	T <sub>stg</sub>	-50 to 150	°C

Note 1: V<sub>in</sub> (1) pin: V<sub>e</sub>, LA

Note 2: V<sub>in</sub> (2) pin: I<sub>dc</sub>, HU, HV, HW

Note 3: Apply pulse

Note 4: Package thermal resistance (θ<sub>j-c</sub> = 1°C/W) with an infinite heat sink at Ta = 25°C

Note 5: The operating temperature range is determined according to the P<sub>D</sub> MAX – Ta characteristics.

**Recommended operating conditions (Ta = 25°C)**

Characteristics	Symbol	Min	Typ.	Max	Unit
Power supply voltage	V <sub>CC7</sub>	6	7	10	V
	V <sub>CC15</sub>	13.5	15	16.5	
Crystal oscillator frequency	X <sub>in</sub>	2	4	5	MHz
Motor power supply voltage	VB	50	280	400	V
Output current	I <sub>out</sub>	—	1	2	A

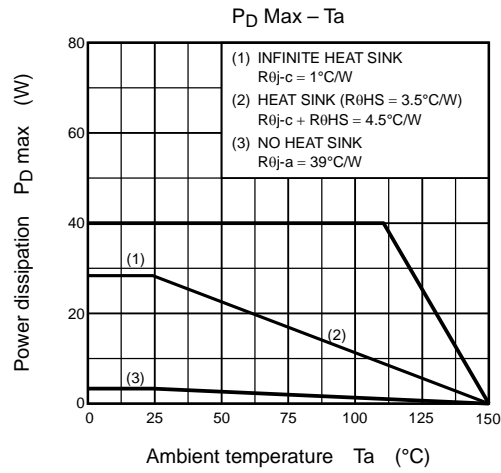

**Electrical Characteristics (Ta = 25°C)**

Characteristics	Symbol	Test Condition	Min	Typ.	Max	Unit	
Current dissipation	$I_B$	$V_B = 400\text{ V}$	—	0.1	0.5	mA	
	$I_{CC15}$	$V_{reg} = \text{OPEN}, V_{CC} = 15\text{ V}$	—	1.1	3		
	$I_{CC7}$	$V_{refout} = \text{OPEN}, V_{CC} = 7\text{ V}$	—	3	6		
	$I_{BS (ON)}$	$V_{BS} = 15\text{ V}, \text{high-side ON}$	—	260	410	$\mu\text{A}$	
	$I_{BS (OFF)}$	$V_{BS} = 15\text{ V}, \text{high-side OFF}$	—	230	370		
Input current	$I_{in (LA)}$	$V_{in} = 5\text{ V}, \text{LA}$	—	25	50	$\mu\text{A}$	
	$I_{in (V_e)}$	$V_{in} = 5\text{ V}, V_e$	—	35	70		
	$I_{in (Hall)}$	$V_{in} = 0\text{ V}, \text{HU, HV, HW}$	-50	-25	—		
Input voltage	$V_{in (Hall)}$	HIGH	HU, HV, HW	$V_{refout-1}$	—	$V_{refout}$	V
		LOW		—	—	0.8	
	$V_{in (V_e)}$	HIGH	PWM Duty 100%	5.1	5.4	5.7	
		Middle	Refresh → Start motor operation	1.8	2.1	2.4	
		LOW	Turned-off → Refresh	0.7	1.0	1.3	
Input hysteresis voltage	$V_H$	HU, HV, HW (Note 6)	—	0.3	—	V	
Input delay time	$V_{DT}$	HU, HV, HW $X_{in} = 4.19\text{ MHz}$	—	4.0	—	$\mu\text{s}$	
	$V_{DC}$	$I_{dc}$ $X_{in} = 4.19\text{ MHz}$	—	4.0	—		
Output saturation voltage	$V_{CEsatH}$	$V_{CC} = 15\text{ V}, I_C = 0.5\text{ A}$	—	2.4	3	V	
	$V_{CEsatL}$	$V_{CC} = 15\text{ V}, I_C = 0.5\text{ A}$	—	2.4	3		
Output voltage	$V_{FG (H)}$	$I_{OUT} = 1\text{ mA}$ FG	$V_{refout-1.0}$	$V_{refout-0.2}$	—	V	
	$V_{FG (L)}$	$I_{OUT} = -1\text{ mA}$ FG	—	0.2	1.0		
	$V_{refout}$	$I_{OUT} = 30\text{ mA}$ $V_{refout}$	4.5	5.0	5.5		
	$V_{reg}$	$I_{OUT} = 30\text{ mA}$	6.5	7	7.5		
FRD forward voltage	$V_{FH}$	$I_F = 0.5\text{ A}, \text{high-side}$	—	1.3	2.0	V	
	$V_{FL}$	$I_F = 0.5\text{ A}, \text{low-side}$	—	1.3	2.0		
BSD forward voltage	$V_F (BSD)$	$I_F = 500\text{ }\mu\text{A}$	—	0.9	1.2	V	
Current detection	$V_{dc}$	$I_{dc}$	0.47	0.5	0.53	V	
Thermal shutdown protection	TSD	(Note 7)	150	165	200	$^{\circ}\text{C}$	
	TSDhys		—	20	—		
$V_{CC15}$ undervoltage protection for driver	$V_{CC15 (H)}$	Undervoltage positive-going threshold	10.5	11.5	12.5	V	
	$V_{CC15 (L)}$	Undervoltage negative-going threshold	10	11	12		
VBS undervoltage protection for driver	$V_{BS (H)}$	Undervoltage positive-going threshold	8.5	9.5	10.5	V	
	$V_{BS (L)}$	Undervoltage negative-going threshold	8	9	10		
$V_{CC7}$ undervoltage protection for controller	$V_{CC7 (H)}$	Undervoltage positive-going threshold	4.2	4.5	4.8	V	
	$V_{CC7 (L)}$	Undervoltage negative-going threshold	3.7	4.0	4.3		
Output turn-on/-off delay time	$t_{on}$	$V_{BB} = 280\text{ V}, V_{CC} = 15\text{ V}, I_C = 0.5\text{ A}$	—	1.5	3	$\mu\text{s}$	
	$t_{off}$	$V_{BB} = 280\text{ V}, V_{CC} = 15\text{ V}, I_C = 0.5\text{ A}$	—	1.2	3		
Dead time	$t_{dead}$	$X_{in} = 4.19\text{ MHz}$	1.5	1.8	—	$\mu\text{s}$	
FRD reverse recovery time	$t_{rr}$	$V_{BB} = 280\text{ V}, V_{CC} = 15\text{ V}, I_C = 0.5\text{ A}$	—	200	—	ns	

Note 6 and Note 7: Toshiba does not implement testing before shipping.

## Functional Description

### 1. Basic operation

The motor is driven by the square-wave turn-on signal based on a positional signal. When the positional signal reaches number of rotations  $f = 5$  Hz or higher, the rotor position is estimated according to the positional signal and a modulation wave is generated. The modulation wave and the triangular wave are compared; then the sine-wave PWM signal is generated and the motor is driven.

From start to 5 Hz: When driven by square wave (120° turn-on)  $f = f_{osc}/(2^{12} \times 32 \times 6)$

5 Hz~: When driven by sine-wave PWM (180° turn-on); when  $f_{osc} = 4$  MHz, approx. 5 Hz

### 2. $V_e$ voltage command input and bootstrap power supply

- (1) Voltage command input: When  $V_e \leq 1.0$  V  
U, V and W signals are stopped to protect IGBTs
- (2) Voltage command input: When  $1.0$  V  $< V_e \leq 2.1$  V  
The low-side IGBTs are turned on at a fixed frequency (carrier frequency) (duty cycle: 8%).
- (3) Voltage command input: When  $V_e > 2.1$  V  
The U, V and W signals are driven out during sine wave drive.  
The low-side IGBTs are forced to on at fixed frequency (carrier frequency) during square-wave drive (duty cycle: 8%).

Note 1: At startup, the low-side IGBTs must be turned on for a fixed period at  $1.0$  V  $< V_e \leq 2.1$  V to charge the high-side IGBT power supply.

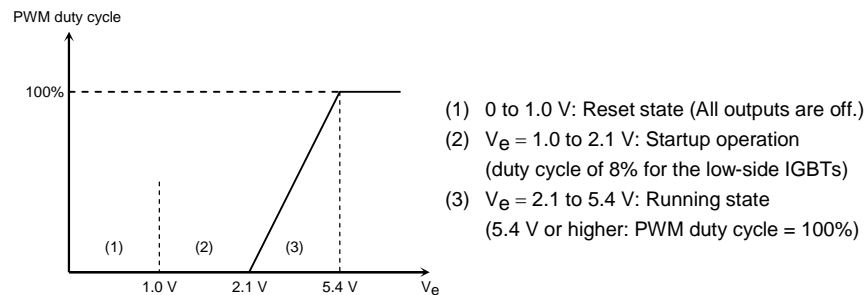

### 3. Dead time function: upper/lower transistor output off-time

When the motor is driven by sine-wave PWM, dead time is digitally generated inside the IC to prevent short circuit caused by the simultaneously turning on of upper and lower external power devices. When a square wave is generated in full-duty cycle mode, the dead time function is turned on to prevent a short circuit.

Internal Counter	$T_{OFF}$
$8/f_{osc}$	1.9 $\mu$ s

$T_{OFF}$  values above are obtained when  $f_{osc} = 4.19$  MHz.  
 $f_{osc}$  = reference clock (crystal oscillation)

### 4. Correcting the lead angle

The lead angle can be corrected in the turn-on signal range from 0 to 58° in relation to the induced voltage.

Analog input from LA pin (0 V to 5 V divided by 32)

0 V = 0°

5 V = 58° (when more than 5 V is input, 58°)

## 5. Setting the carrier frequency

This function sets the triangular wave cycle (carrier cycle) necessary for generating the PWM signal. (The triangular wave is used for forcibly turning on the lower transistor when the motor is driven by square wave.)

$$\text{Carrier cycle} = f_{\text{osc}}/252 \text{ (Hz)} \quad f_{\text{osc}} = \text{reference clock (crystal oscillation)}$$

## 6. Outputting the reverse rotation detection signal

This function detects the motor rotation direction every electrical angle of 360°. This function judges whether the actual direction of a rotating motor coincides with that of the internal reference voltage.

Actual Motor Rotating Direction	REV Pin	Drive Mode
CW (forward)	HIGH	Square waveform (120° turn-on mode)
CCW (reverse)	LOW	Sine-wave waveform (180° turn-on mode)

\*: CW or CCW of the motor is determined by the direction of the Hall signal, which is specified in the timing chart on page 9.

\*: When the REV pin is set to LOW, and the Hall signal is higher than 5 Hz, sine-wave drive mode is turned on.

## 7. Protecting input pin

### (1) Overcurrent protection (Pin $I_{dc}$ )

When the DC-link-current exceeds the internal reference voltage, gate block protection is performed. Overcurrent protection is released for each carrier frequency.

Reference voltage = 0.5 V (typ.)

### (2) Positional signal abnormality protection

Output is turned off when the positional signal is HHH or LLL; otherwise, it is restarted.

### (3) Monitor protection for VCC7/ VCC15 low supply voltage

For power supply on/off outside the operating voltage range, the U, V and W drive outputs are turned off and the motor is stopped when there is a power supply fault.

< VCC7 >

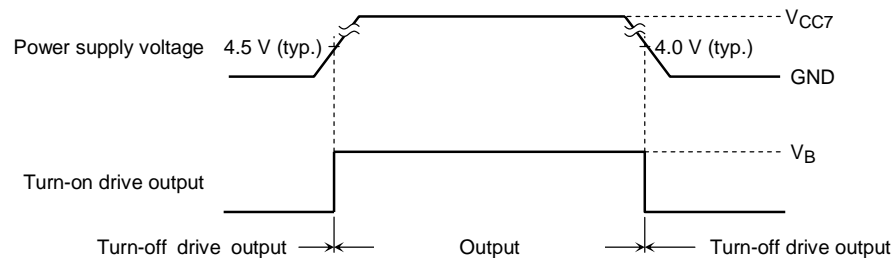

< VCC15 >

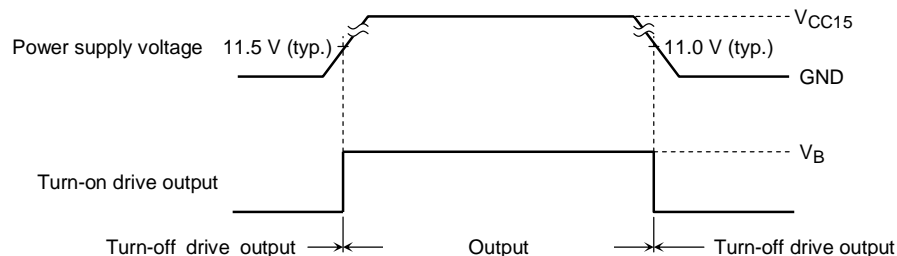

- (4) Monitor protection for VBS Bootstrap power supply  
When VBS power supply is lowered, the high-side IGBT is turned off.

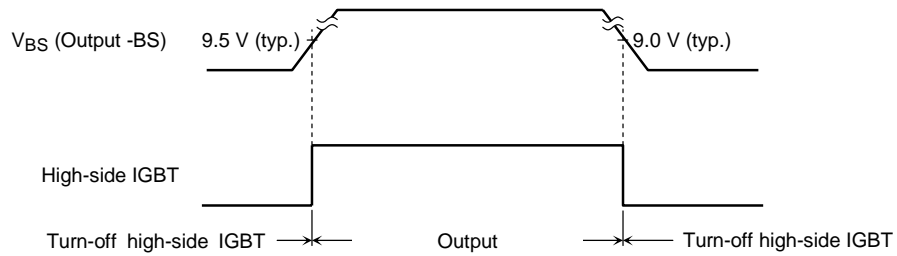

- (5) Overheat protection  
The overheat protection circuit will operate and all IGBTs will be turned off if the chip temperature becomes abnormally high due to internal or external heat generation.

$$T_{SD} = 165^{\circ}\text{C (typ.)} \quad T_{SDhys} = 20^{\circ}\text{C (typ.)}$$

After the overheat protection circuit is turned on, the return temperature is  $145^{\circ}\text{C (typ.)}$ .



### Timing Chart

- CW (forward) mode (CW mode means that the Hall signal is input in the order shown below.)

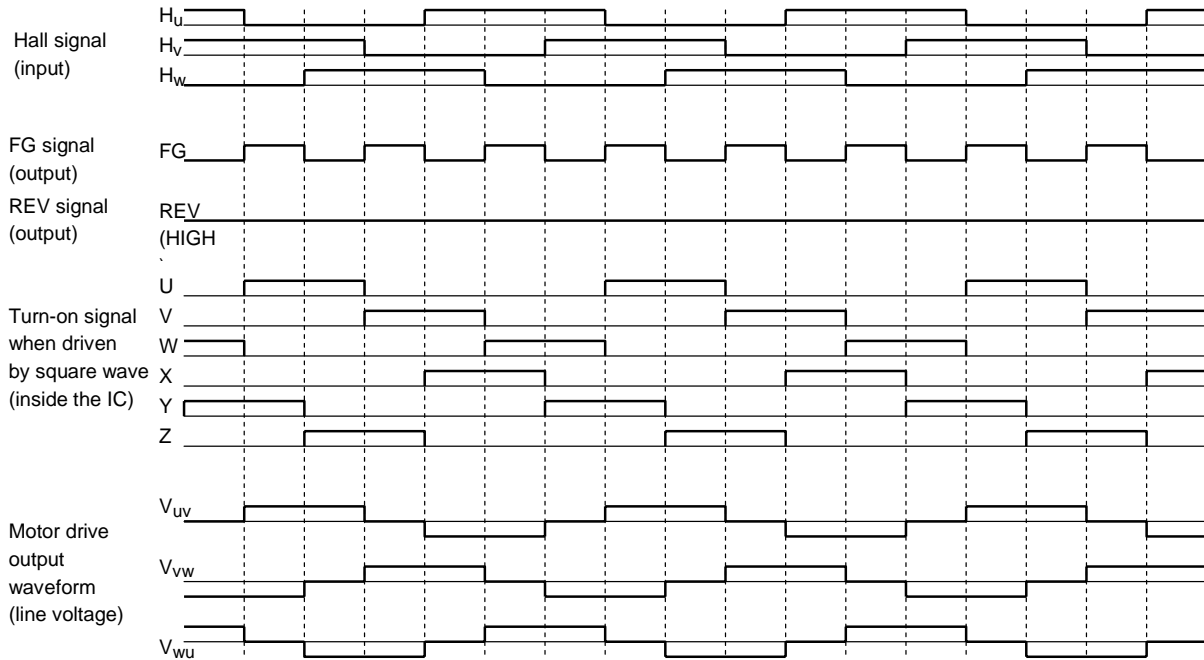

\* The waveform of actual operation is the PWM

- CCW (reverse) mode (CCW mode means that the Hall signal is input in the order shown below.)

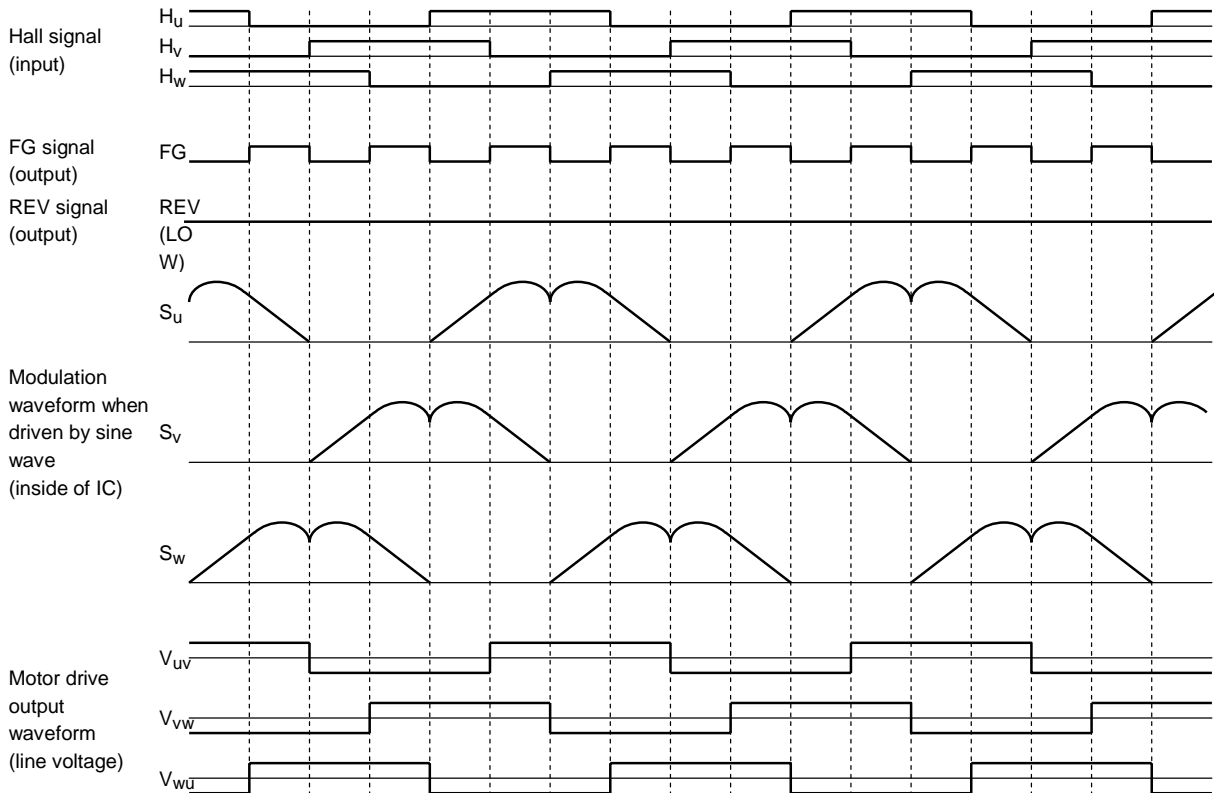

\* The waveform of actual operation is the PWM

Example of Application Circuit

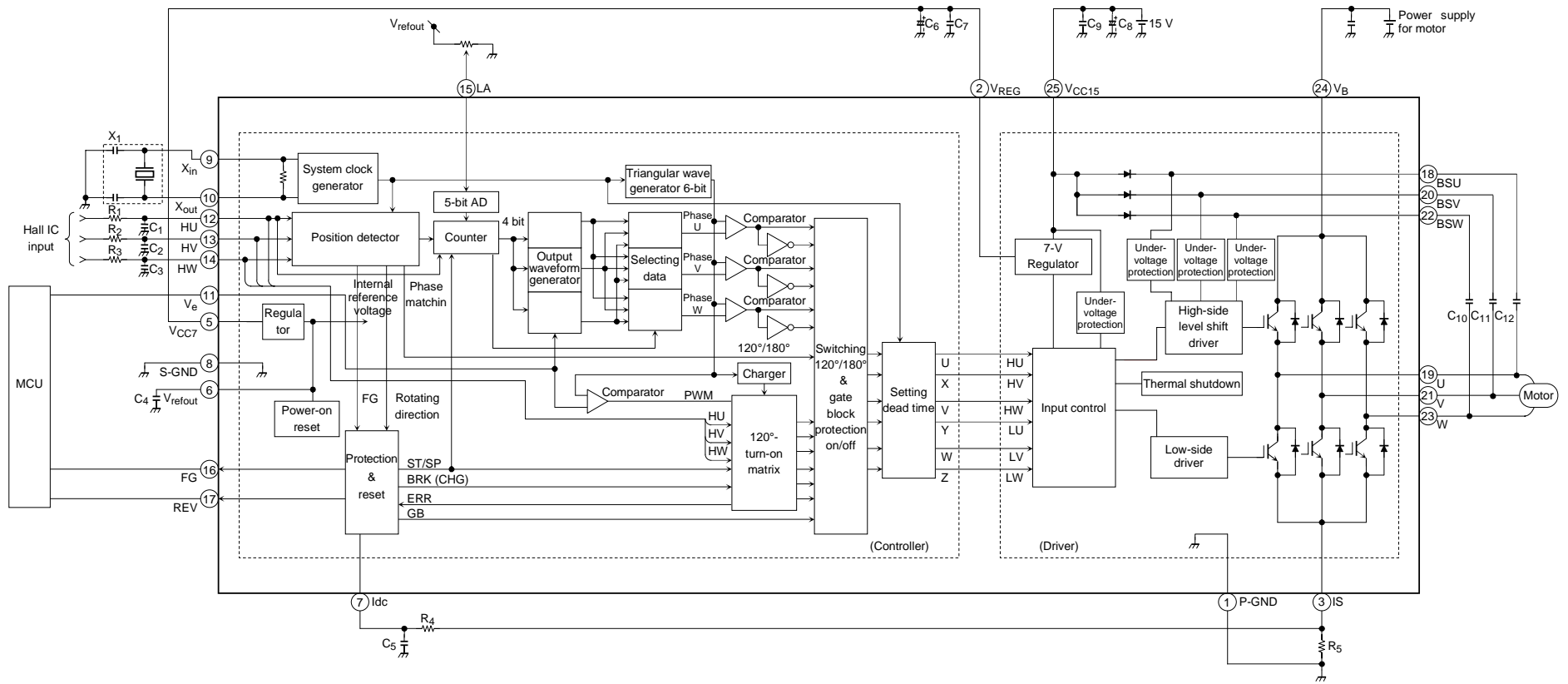

**External Parts**

Symbol	Purpose	Recommended value	Note
X <sub>1</sub>	Internal clock generation	4.19 MHz	(Note 1)
C <sub>1</sub> , C <sub>2</sub> , C <sub>3</sub>	Noise absorber	10 V/1000 pF	(Note 2)
R <sub>1</sub> , R <sub>2</sub> , R <sub>3</sub>		10 kΩ	
C <sub>4</sub>	V <sub>refout</sub> oscillation protection	10 V/0.1 μF~1.0 μF	(Note 3)
C <sub>5</sub>	Noise absorber	10 V/1000pF	(Note 2)
R <sub>4</sub>		5.1 kΩ	
R <sub>5</sub>	Overcurrent detection	0.62 Ω ± 1% (1 W)	(Note 4)
C <sub>6</sub>	V <sub>REG</sub> power supply stability	16 V/1.0 μF~10 μF	(Note 3)
C <sub>7</sub>		10 V/1000 pF	
C <sub>8</sub>	V <sub>CC15</sub> power supply stability	25 V/0.1 μF	(Note 3)
C <sub>9</sub>		25 V/10 μF	
C <sub>10</sub> , C <sub>11</sub> , C <sub>12</sub>	Bootstrap capacitor	25 V/2.2 μF	(Note 5)

Note 1: For carrier frequency and dead time, connect a 4.19 MHz ceramic resonator.

Note 2: These parts are used as a low-pass filter for noise absorption. Test to confirm noise filtering, then set the filter time-constant.

Note 3: This part is used as a capacitor for power supply stability. Adjust the part to the application environment as required. When mounting, place it as close as possible to the base of the leads of this product to improve the noise elimination.

Note 4: This part is used to set the value for overcurrent detection.  $I_{out(max)} = V_{dc} \div R_5$  ( $V_{dc} = 0.5$  V (typ.))

Note 5: The required bootstrap capacitance value varies according to the motor drive conditions. The voltage stress for the capacitor is the value of V<sub>CC15</sub>.

**Other Precautions**

A short circuit between the outputs, or between output and supply or ground may damage the device. Peripheral parts may also be damaged by overvoltage and overcurrent. Design the output lines, VCC and GND lines so that short circuits do not occur.

Also be careful not to insert the IC in the wrong direction because this could destroy the IC.

In turning on the power, first supply Vcc15 and confirm its stability; then apply Vcc7 and the driving input signal. Vcc15 and VB may be turned on in either order. In turning off the power, take care not to cut off the VB line by relay while the motor is spinning. Doing so may cause the IC to break down by cutting the current-producing route for VB.

The TB6581H/HG is sensitive to electrostatic discharge. Handle with care.

The product should be mounted by the solder-flow method. The preheating time is from 60 to 120 seconds at 150°C. The maximum heat is 260°C, to be applied within 10 seconds and as far as the lead stopper.

**Package Dimensions**

HZIP25-P-1.00K

Unit: mm

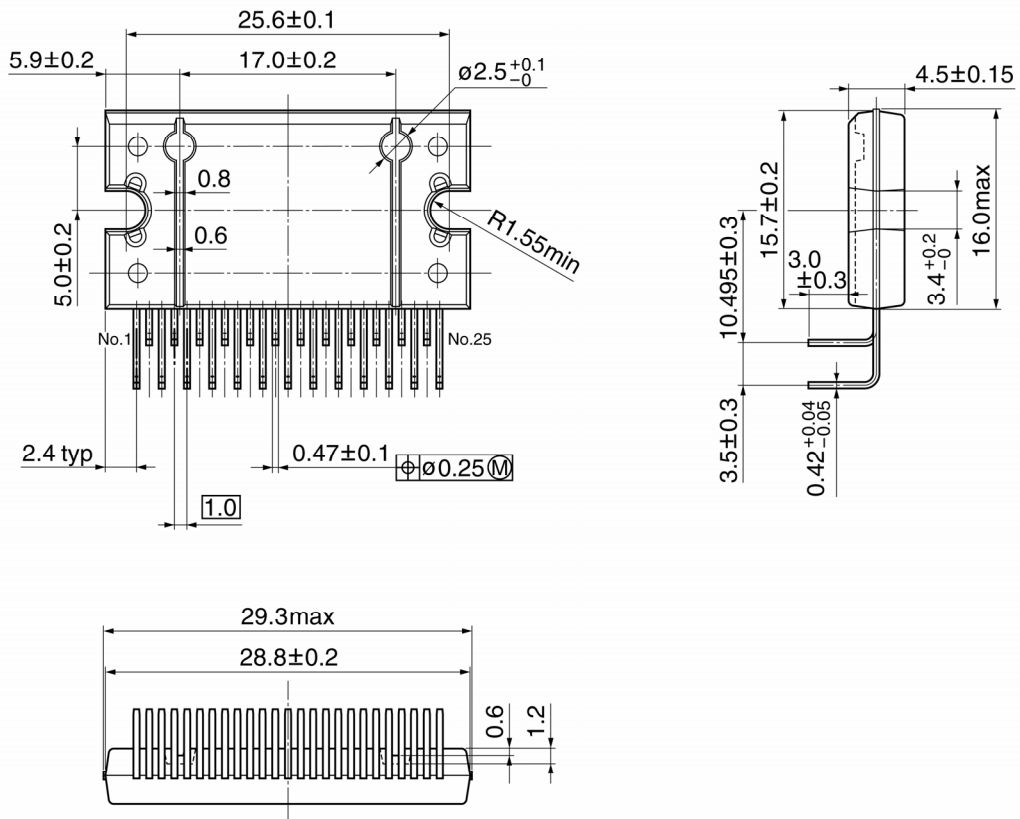

Weight: 7.7 g (typ.)

## Notes on contents

### 1. Block Diagrams

Some functional blocks, circuits, or constants may be omitted or simplified in the block diagram for explanatory purposes.

### 2. Equivalent Circuits

The equivalent circuit diagrams may be simplified or some parts of them may be omitted for explanatory purposes.

### 3. Timing Charts

Timing charts may be simplified for explanatory purposes.

### 4. Maximum Ratings

The absolute maximum ratings of a semiconductor device are a set of specified parameter values that must not be exceeded during operation, even for an instant.

If any of these ratings are exceeded during operation, the electrical characteristics of the device may be irreparably altered, in which case the reliability and lifetime of the device can no longer be guaranteed.

Moreover, any exceeding of the ratings during operation may cause breakdown, damage and/or degradation in other equipment. Applications using the device should be designed so that no maximum rating will ever be exceeded under any operating conditions.

Before using, creating and/or producing designs, refer to and comply with the precautions and conditions set forth in this document.

### 5. Application Circuits

The application circuits shown in this document are provided for reference purposes only. Thorough evaluation is required in the mass production design phase.

In furnishing these examples of application circuits, Toshiba does not grant the use of any industrial property rights.

### 6. Test Circuits

Components in test circuits are used only to obtain and confirm device characteristics. These components and circuits are not guaranteed to prevent malfunction or failure in application equipment.

## Handling of the IC

Ensure that the product is installed correctly to prevent breakdown, damage and/or degradation in the product or equipment.

## Over-current protection and heat protection circuits

These protection functions are intended only as a temporary means of preventing output short circuits or other abnormal conditions and are not guaranteed to prevent damage to the IC.

If the guaranteed operating ranges of this product are exceeded, these protection features may not operate and some output short circuits may result in the IC being damaged.

The over-current protection feature is intended to protect the IC from temporary short circuits only.

Short circuits persisting over long periods may cause excessive stress and damage the IC. Systems should be configured so that any over-current condition will be eliminated as soon as possible.

## Counter-electromotive force

When the motor reverses or stops, the effect of counter-electromotive force may cause the current to flow to the power source.

If the power supply is not equipped with sink capability, the power and output pins may exceed the maximum rating.

The counter-electromotive force of the motor will vary depending on the conditions of use and the features of the motor. Therefore make sure there will be no damage to or operational problem in the IC, and no damage to or operational errors in peripheral circuits caused by counter-electromotive force.

**RESTRICTIONS ON PRODUCT USE**

030619EBA

- The information contained herein is subject to change without notice.
- The information contained herein is presented only as a guide for the applications of our products. No responsibility is assumed by TOSHIBA for any infringements of patents or other rights of the third parties which may result from its use. No license is granted by implication or otherwise under any patent or patent rights of TOSHIBA or others.
- TOSHIBA is continually working to improve the quality and reliability of its products. Nevertheless, semiconductor devices in general can malfunction or fail due to their inherent electrical sensitivity and vulnerability to physical stress. It is the responsibility of the buyer, when utilizing TOSHIBA products, to comply with the standards of safety in making a safe design for the entire system, and to avoid situations in which a malfunction or failure of such TOSHIBA products could cause loss of human life, bodily injury or damage to property.  
In developing your designs, please ensure that TOSHIBA products are used within specified operating ranges as set forth in the most recent TOSHIBA products specifications. Also, please keep in mind the precautions and conditions set forth in the "Handling Guide for Semiconductor Devices," or "TOSHIBA Semiconductor Reliability Handbook" etc..
- The TOSHIBA products listed in this document are intended for usage in general electronics applications (computer, personal equipment, office equipment, measuring equipment, industrial robotics, domestic appliances, etc.). These TOSHIBA products are neither intended nor warranted for usage in equipment that requires extraordinarily high quality and/or reliability or a malfunction or failure of which may cause loss of human life or bodily injury ("Unintended Usage"). Unintended Usage include atomic energy control instruments, airplane or spaceship instruments, transportation instruments, traffic signal instruments, combustion control instruments, medical instruments, all types of safety devices, etc.. Unintended Usage of TOSHIBA products listed in this document shall be made at the customer's own risk.
- The products described in this document are subject to the foreign exchange and foreign trade laws.
- TOSHIBA products should not be embedded to the downstream products which are prohibited to be produced and sold, under any law and regulations.